



Models 1GA/2GA

INSTALLATION, OPERATION AND MAINTENANCE INSTRUCTIONS

Table of Contents

Introduction and Safety	2
Data Plate Interpretation	7
Product Description	8
General Design of a 15GDS/20GDS Pump.....	9
Installation.....	11
Electrical Connections	13
Cable Chart	15
Colors and Markings of Leads	16
Transportation and Storage.....	17
Operation	18
Care and Maintenance.....	19
Oil Change	20
Service Log.....	22

Owners Information

Complete this information for your records.
Model number and serial number may be found
on the tag mounted to the motor adapter.

Model Number _____

Serial Number _____

Dealer _____

Dealer phone number _____

Date of purchase _____

Date of installation _____

I. Introduction and Safety

Introduction

Description

This manual provides instructions for the Installation, Operation and Maintenance of the Goulds Water Technology 1GA/2GA pumps.

Requirement

This manual must be read and understood before installation and start-up. Goulds Water Technology shall not be liable for physical injury, damage or delays caused by a failure to observe the instructions for installation, operation and maintenance contained in this manual.

Content

This instruction manual covers several different pump models that all have similar power end configurations. Most assembly, disassembly and inspection procedures are the same for all the pumps. However, where there are differences, they are called out separately within the manual. The design, materials and workmanship incorporated in the construction of Goulds Water Technology makes them capable of giving long, trouble free service. The life and satisfactory service of any mechanical unit, however, is enhanced and extended by correct application, proper installation, periodic inspection, condition monitoring and careful maintenance. This instruction manual was prepared to assist operators in understanding the construction and the correct methods of installing, operating and maintaining these pumps.

Key Topics

- Data Plate Interpretation
- Product Description
- General Design
- Installation
- Electrical Connections
- Cable Chart
- Transportation and Storage
- Operation
- Care and Maintenance
- Oil Change

Safety

It is extremely important that you read, understand, and follow the safety messages and regulations carefully before handling a Goulds Water Technology product. They are published to help prevent

- personal accidents and health problems
- damage to the product
- product malfunction

Observe all safety messages highlighted in other sections of this manual.





A pump is a pressure-containing device with rotating parts that can be dangerous.



Caution: You must observe the instructions for installation, operation, and maintenance contained in this manual. Failure to do so could result in physical injury, damage, or delays.

Safety message levels

Table 1: Definitions

Safety message level	Indication
 <u>Danger:</u>	Indicates a hazardous situation which, if not avoided, will result in death or serious injury.
 <u>Warning:</u>	Indicates a hazardous situation which, if not avoided, could result in death or serious injury.
 <u>Caution:</u>	Indicates a hazardous situation which, if not avoided, could result in minor or moderate injury.
<u>Note:</u>	Indicates a potential situation which, if not avoided, may result in undesirable results or state. Indicates a practice not related to personal injury.
 <u>Electrical Hazard:</u>	Indicates the possibility of electrical risks if direction are not applied in a proper manner.

Environmental safety

Preventive measures for the working area

Always keep the pump station clean to avoid and/or discover emissions.

Recycling guidelines

Always recycle according to the guidelines listed below:

1. Follow local laws and regulations regarding recycling if the unit or parts are accepted by an authorized recycling company.
2. If the first guideline is not applicable then return the unit or parts to the nearest Goulds Water Technology representative.

Waste and emissions

Observe these safety regulations regarding waste and emissions:

- Dispose appropriately of all waste.
- Handle and dispose of the pumpage in compliance with applicable environmental regulations.
- Clean-up all spills in accordance with safety and environmental procedures.
- Report all environmental emissions to the appropriate authorities.

Reference for electrical installation

For electrical installation recycling requirements, consult your local electric utility.

User health and safety

Safety equipment

Use safety equipment according to the company regulations. The following safety equipment should be used within the working area depending on the fluid being pumped:

- helmet
- safety goggles (with side shields)
- protective shoes
- protective gloves
- gas mask
- hearing protection

Note: The noise level of the product is lower than 70 dB. However, the noise level of 70 dB may be exceeded in some installations and at certain operating points on the performance curve. Make sure that you understand the noise level requirements in the environment where the pump is installed. Failure to do so may result in hearing loss or violation of local laws.

The working area

Observe these regulations and warnings in the working area:

- Always keep the work area clean.
- Pay attention to the chemical and physical characteristics of the gas and vapors present in hazardous areas.
- Avoid all electrical dangers. Pay attention to the risks of electric shock or arc flash hazards.

Product and product positioning requirements

Observe these requirements for the product and the product positioning:

- Never operate a pump unless safety devices are installed.
- Three-phase motors must have a properly sized starter with properly sized heaters to provide overload and under voltage protection. Single-phase motors have built-in overload protectors.
- Never start a pump without the proper priming.
- Never run a pump below the minimum rated flow or with any suction or discharge valve closed.

Electrical connections

Electrical connections must be made by authorized electricians in compliance with all international, national, state and local rules.

Observe the following regulations and warnings for electrical connections.

- Make sure that the product is isolated from the power supply and can not be energized by mistake. This rule applies to the control circuit as well.
- Make sure that the thermal contacts are connected to a protection circuit according to the product approvals, and that they are in use.

Observe the following regulations for grounding connections.

Table 2: Grounding

Grounding regulation	Comment
All electric equipment must be grounded.	This rule applies to pumps and mixers as well as monitoring equipment.

Precautions before work

Observe the following safety precautions before working with or in connection with the product:

- Make sure that there are no poisonous gases within the work area.
- Provide a suitable barrier around the work area, for example a guard rail.
- Make sure that all safety guards are in place and secure.
- Make sure that the equipment is properly insulated when operating at extreme temperatures.
- Allow all system and pump components to cool before you handle them.
- Make sure that you have a clear path of retreat.
- Make sure that the product cannot roll or fall over and injure people or damage property.
- Make sure that the lifting equipment is in good condition.
- Use a lifting harness, a safety line, and a breathing device as required.
- Make sure that the product has been thoroughly cleaned.
- Make sure that a first-aid kit is close at hand.
- Check the explosion risk before welding or using electric hand tools.

Precautions during work

Observe the following safety precautions when working with or in connection with the product:

- Never work alone.
- Stay clear of suspended loads.
- Always lift the product by its lifting device.
- Beware of the risk of a sudden start if the product is used with an automatic level control.
- Beware of the starting jerk, which can be powerful.
- Rinse the components in water after disassembling the pump.
- Do not exceed the maximum working pressure of the pump.
- Do not open any vent or drain valves or remove any plugs while the system is pressurized. Ensure that the pump is isolated from the system and that pressure is relieved before you disassemble the pump, remove plugs, or disconnect piping.

- Always bear in mind the risk of:
 - electrical accidents
 - burn injuries

Clean chemicals from the eyes

1. Forcibly hold the eyelids apart with the fingers.
2. Rinse the eyes for at least 15 minutes. Use an eyewash or running water.
3. Seek medical attention.

Clean chemicals from the body

1. Remove contaminated clothing.
2. Wash the skin with soap and water for at least 1 minute.
3. If required, seek medical attention.

Product approval standards

Regular standards

All electrical ratings and performance of the motors comply with UL, CSA and NEMA standards.

Product warranty

Personnel requirements

All work on the product must be carried out by certified electricians and Goulds Water Technology authorized service centers.

Goulds Water Technology disclaims all responsibility for work done by untrained and unauthorized personnel.

Modification and spare parts

Modifications or changes to the product/installation should only be carried out after consulting with Goulds Water Technology. Original spare parts and accessories authorized by Goulds Water Technology are essential for compliance. The use of other parts can invalidate any claims for warranty or compensation and explosion-proof approvals.

Warranty claim

For warranty claim, contact your Goulds Water Technology representative.

II. Data Plate Interpretation

General Data Plate

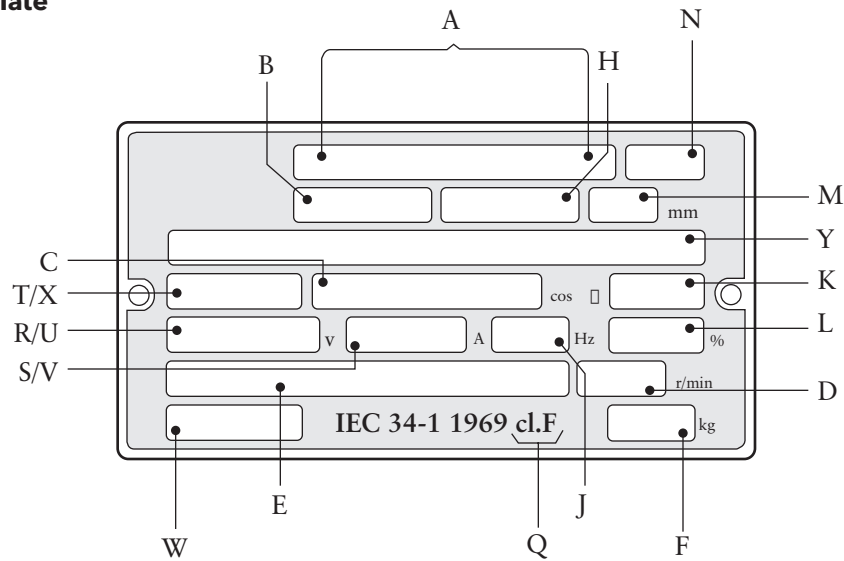

A	Internal	L	Operating duty, cont./int.
B	Serial number	M	Impeller/propeller diameter
C	Shaft power	N	Factory code
D	Rated speed	Q	Temperature class
E	Product number	R/U	Rated voltage
F	Weight	S/V	Rated current
H	Curve code, first digit = number of poles	T/X	Stator connection
J	Number of phases, type of current, frequency	W	Special order number
K	Power factor	Y	Motor number

Approval Plate

This approval plate applies to an explosion-proof submersible Goulds Water Technology pump. The plate is used together with the general data plate on the pump.

FM: Factory Mutual
 Class I, Division I, Group C and D
 Class II and III, Division I, Group E, F and G

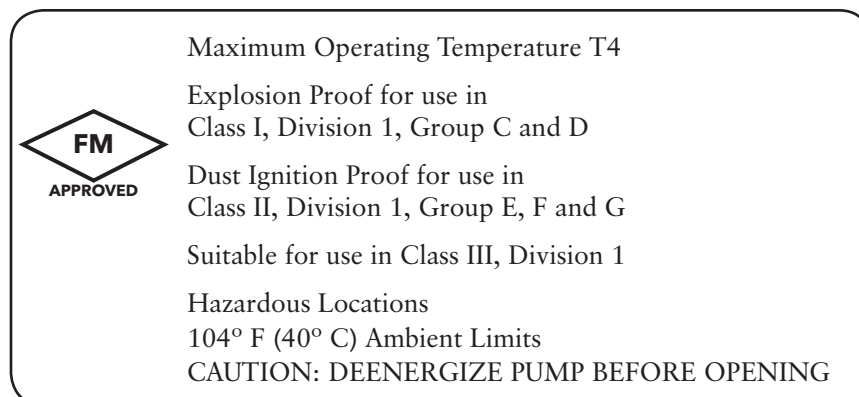

III. Product Description

Introduction

Thank you for buying a submersible Goulds Water Technology pump. In this Installation, Care and Maintenance manual, you will find general information on how to install and service the 1GA or 2GA pump to give it a long and reliable life. In the Parts List you will find all the specific technical data for your pump.

Application

This Installation, Care and Maintenance manual applies to a submersible Goulds Water Technology 1GA or 2GA pump. If you have bought an explosion proof pump (please see approval plate on your pump or Parts List) special handling instructions apply as described in this document.

The pump is intended to be used for pumping of sewage for high head application.

The pumps must not be used in highly corrosive liquids. See pH limits below.

The pump is available for permanent installation in a sump or portable installation.

For further information on applications, contact your nearest Goulds Water Technology wastewater representative.

Specific Technical Data

For specific technical data regarding your pump, please see Parts List.

General Technical Data

Liquid Temperature: Maximum 104° F (40° C). The pump can be operated at full load only if fully submerged.

Liquid Density: Maximum 9.2 lb per US gallon (1100 kg/m³)

The pH of the Pumped Liquid: 6-13 (cast iron pumps)

Depth of Immersion: Maximum 65 ft (20 m)



In some installations and at certain operating points on the performance curve, the noise level of 70 dB or the noise level specified for the actual pump may be exceeded.

Only ex-approved pumps may be used in an explosive or flammable environment.

Warranty Claim

The pumps are high quality products with expected reliable operation and long life. However, should the need arise for a warranty claim, please contact your Goulds Water Technology representative.

IV. General Design of a 1GA/2GA Pump

Design

The pump is a submersible, electric motor-driven product.

1. Impeller

The impeller has a cutter mounted at the inlet which grinds solids.

2. Shaft Seals

The pump has two mechanical face seals - one inner and one outer, with an intermediate oil housing.

3. Shaft

The shaft is delivered with the rotor as an integral part. Shaft material: stainless steel.

4. Bearings

The support bearing of the rotor consists of a single-row ball bearing. The main bearing of the rotor consists of a two-row angular contact ball bearing.

5. Oil Housing

The oil lubricates and cools the seals and acts as a buffer between the pump housing and the electric motor.

6. Motor

Squirrel-cage 1-phase or 3-phase induction motor.

The motor can be started by direct on-line or star-delta starting.

The motor can be run continuously or intermittently with a maximum of 15 evenly spaced starts per hour.

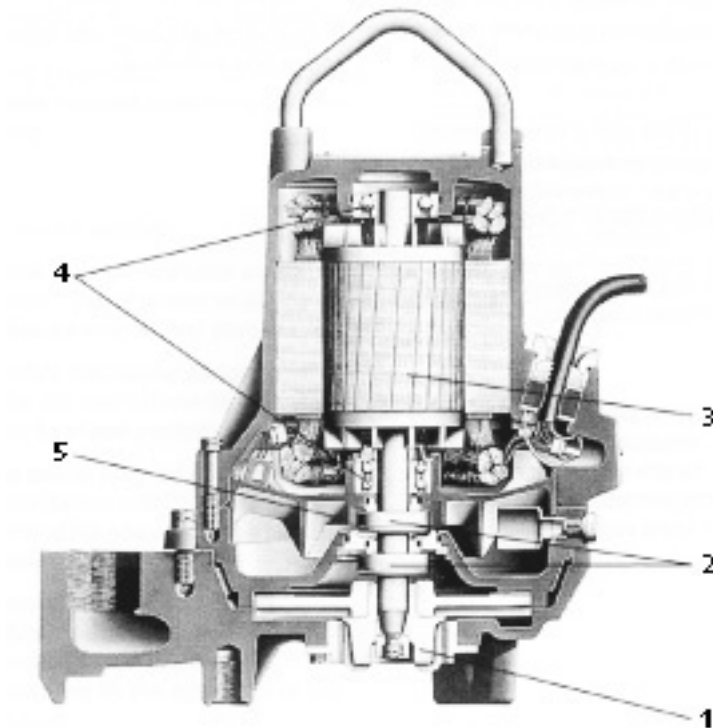

The motors are tested in accordance with IEC 34-1, 1969.

The stator is insulated in accordance with class F (310° F, 155° C). The motor is designed to deliver its rated output at $\pm 5\%$ variation from the rated voltage. Without overheating the motor, $\pm 10\%$ variation from the rated voltage can be accepted provided that the motor does not run continuously at full load. The motor is designed to operate at a voltage imbalance of up to 2% between the phases.

Monitoring Equipment

The stator incorporates thermal contacts connected in series.

The pump can be equipped with sensors for sensing water in the stator housing.

V. Installation

Handling Equipment

Lifting equipment is required for handling the pump.



Stay clear of suspended loads.

Always lift the pump by its lifting handle, never by the motor cable or the hose.

The minimum height between the lifting hook and the floor shall be sufficient to lift the pump out of the sump.

The lifting equipment shall be able to hoist the pump straight up and down in the sump, preferable without the need for resetting the lifting hook.

Oversize lifting equipment could cause damage if the pump should stick when being lifted.

Make sure that the lifting equipment is securely anchored.

General Recommendations

To ensure proper installation, please see the dimensions on the dimensional drawing in the Parts List.

NOTE: The end of the cable must not be submerged. It must be above flood level, as water may penetrate through the cable into the junction box or the motor.

Check that the lifting handle and chain are in good condition.

For automatic operation of the pump (level control), it is recommended that the level regulators be used at low voltage. The data sheet delivered with the regulators gives the permissible voltage. Local rules may specify otherwise.

Clean out all debris from the sump before the pump is lowered down and the station is started.



Special rules apply to installation in explosive atmosphere. Intrinsically safe circuits are normally required (Ex I) for the automatic level control system by level regulators.

Safety Precautions

In order to minimize the risk of accidents in connection with the service and installation work, the following rules should be followed:

1. Never work alone. Use a lifting harness, safety line and a respirator as required. Do not ignore the risk of drowning!
2. Make sure there are no poisonous gases within the work area.
3. Check the explosion risk before welding if using electric hand tools.
4. Do not ignore health hazards. Observe strict cleanliness.
5. Bear in mind the risk of electrical accidents.

6. Make sure that the lifting equipment is in good condition.
 7. Provide a suitable barrier around the work area, e.g. a guard rail.
 8. Make sure you have a clear path of retreat!
 9. Use safety helmet, safety goggles and protective shoes.
 10. All personnel who work with sewage systems must be vaccinated against diseases to which they may be exposed.
 11. A first-aid kit must be close at hand.
 12. Note that special rules apply to installation in explosive atmosphere.
- Follow all other health and safety rules and local codes and ordinances.

VI. Electrical Connections



Before starting work on the pump, make sure that the pump and the control panel are isolated from the power supply and cannot be energized.

If the pump is equipped with automatic level control, there is a risk of sudden restart.

All electrical equipment must be earthed. This applies to both pump equipment and any monitoring equipment. Failure to heed this warning may cause a lethal accident. Make sure that the earth lead is correctly connected by testing it.

If persons are likely to come into physical contact with the pump or pumped media (liquid), e.g. on construction sites and farms, the earthed (grounded) socket must have an additional earth-(ground-) fault protection device (GFI) connected.

When pumping near a lake (jetties, beaches, ponds, fountains, etc.) a safety-distance of at least 65 feet (20 m) between the person and the pump is applicable.

The pump must never be placed directly into a swimming pool. If used in connection with swimming pools, special safety regulations apply.



NOTE FOR EX-VERSION: Electrical connections on the explosion-proof motor must be made by authorized personnel. Goulds Water Technology disclaims all responsibility for work done by untrained, unauthorized personnel.

The pump may be used only in accordance with the approved motor data stated on the pump's plates.

Thermal contacts must be connected to protection circuit intended for that purpose according to the approval of the product.

All electrical work shall be carried out under the supervision of an authorized electrician. Local codes and regulations shall be complied with.

Check on the data plate which voltage supply is valid for your pump.

Check that the main voltage and frequency agree with the specifications on the pump data plate.

If the pump can be connected to different voltages, the connected voltage is specified by a yellow sticker.

Connect the motor cable to the starter equipment as illustrated in the wiring diagrams.

Conductors that are not in use must be isolated.

The cable should be replaced if the outer sheath is damaged. Contact a Goulds Water Technology service shop.

Make sure that the cable does not have any sharp bends and is not pinched.

Under no circumstances may the starter equipment be installed in the sump.

NOTE: For safety reasons, the earth conductor should be approximately 2.0" (50 mm) longer than the phase conductors. If the motor cable is jerked loose by mistake, the earth conductor should be the last conductor to come loose from its terminal. This applies to both ends of the cable.

Thermal contacts are incorporated in the stator. The thermal contacts can be connected to maximum 250 V, breaking current maximum 4 A. Goulds Water Technology recommends that they be connected to 24 V over separate fuses to protect the other automatic equipment.

Make sure that the pump is correctly earthed (grounded).

When using a variable-frequency-drive (VFD) special rules have to be followed to avoid clogging and over-heating. Contact your VFD supplier and ask for electrical limitations.

Remember that the starting current in direct online starting can be up to six times higher than the rated current. Make sure that the fuses or circuit breakers are of the proper rating.

The Parts List gives rated current. Fuse rating and cable shall be selected in accordance with local rules and regulations. Note that with long cables, the voltage drop in the cable must be taken into consideration, since the motor's rated voltage is the voltage that is measured at the terminal board in the pump.

The overload protection (motor protection breaker) for direct online starting shall be set to the motor rated current as given on the data plate.

Check the phase sequence in the mains with the phase sequence indicator.

If intermittent operation is prescribed (see Data Plate), the pump shall be provided with control equipment that provides such operation.

Single Phase Operation

The single phase pumps must be equipped with a starter which has start and run capacitors.

A special designed starter is required for the operation of single phase pumps. The connection of the motor cable to the starter is shown in the wiring diagram.

NOTE: It is not possible to change the direction of rotation of a single phase pump by changing the cable conductors on the starter. Please contact your nearest Goulds Water Technology representative.

Monitoring Equipment

The FLS sensor consists of a small float switch for sensing water in the stator housing. Its design makes it suitable for pumps in vertical installations. The FLS sensor is installed in the bottom of the stator housing.

The MiniCas II is a monitoring relay to which FLS is connected.

Check:

- signals and tripping function.
- that relays, lamps, fuses and connections are intact.

Replace defective equipment.

VII. Cable Chart

3-Phase, Direct Online Starting

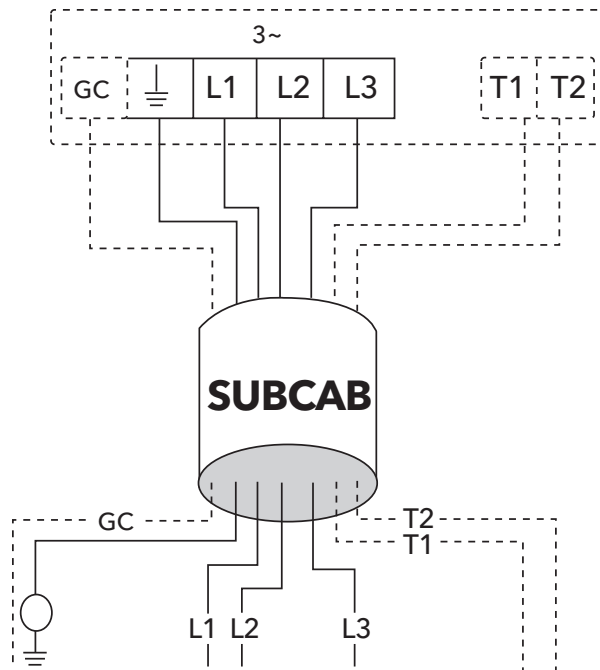

Conductors

Connection Starter

For Canada/USA SUBCAB xAWG/4

brown	L1
gray	L2
black	L3
yellow/green	ground

After 11/1/12 SUBCAB xAWG/6

red	L1
white	L2
black	L3
yellow/green	ground
white	T1*
white	T2*

Single Phase

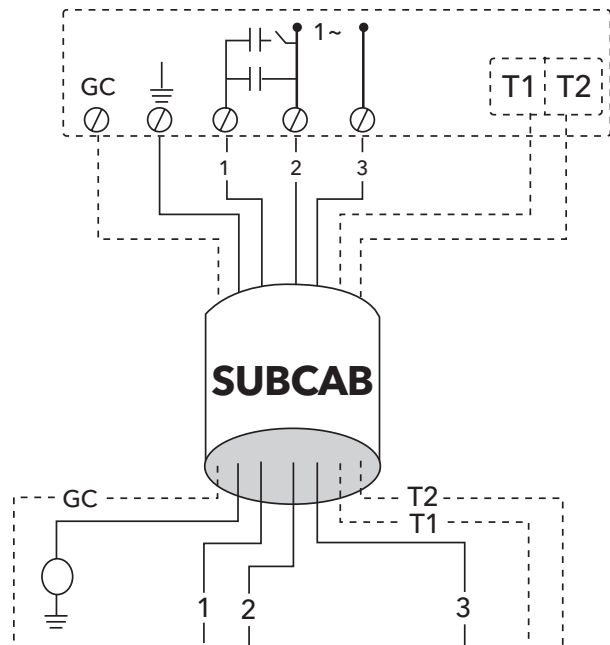

Conductors

Connection Starter

For Canada/USA SUBCAB xAWG/4

brown	1
gray	2
white	3
yellow/green	ground



SUBCAB xAWG/6

red	1
black	2
white	3
yellow/green	ground
orange	T1*
blue	T2*

* Terminal for connection of thermal contacts in the motor and monitoring equipment.

SUBCAB is a registered trademark of Xylem Inc. Flygt AB for electrical cables.

Colors and Markings of Leads

Motor Connection		Mains		SUBCAB 7GX	SUBCAB 4GX	SUBCAB	SUBCAB
Colors and markings of main leads		1~	3~	Screenflex 7GX	Screenflex 4GX	AWG	Screened
Color Standard	Stator Leads	1	L1	BK 1	BN	RD	BN
BN = Brown BK = Black WH = White OG = Orange GN = Green GN/YE = Green-Yellow RD = Red GY = Grey BU = Blue YE = Yellow *SUBCAB AWG **Ground Conductor is stranded around cores GS = Ground Check	U1.U5 RD	2	L2	BK 2	BK	BK	BK
	U2.U6 GN	3	L3	BK 3	GY	WH	GY
	V1.V5 BN		L1	BK 4	—	—	—
	V2.V6 BU		L2	BK 5	—	—	—
	W1.W5 YE		L3	BK 6	—	—	—
	W2.W6 BK						
	T1.T2 WH/YE						
				GN/YE	GN/YE	GN/YE	**Screen/ PE from cores
				Screen (WH)	Screen (WH)	—	Screen (WH)
		GC		—	—	YE	—

772 17 00 (Rev.6)

The Prepared SUBCAB® Cable

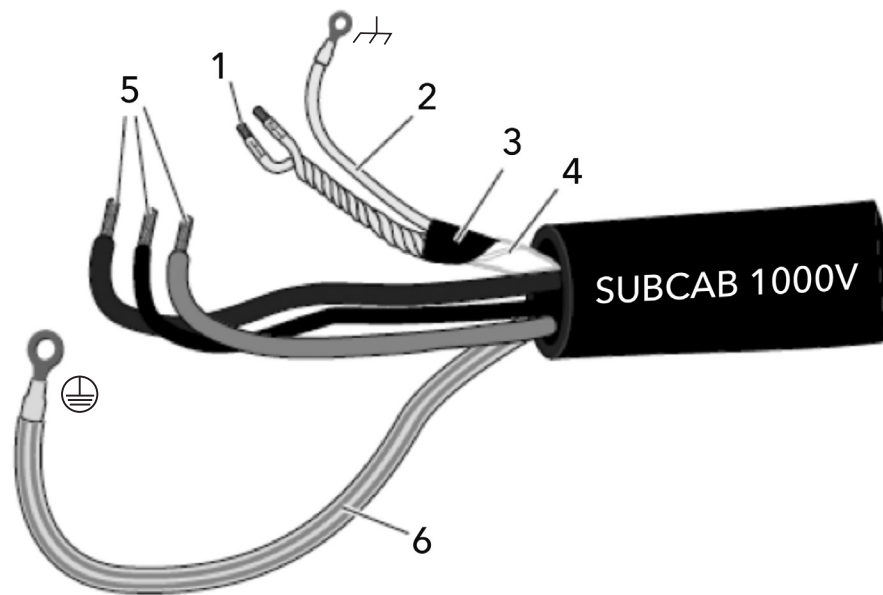

1. T1 + T2 twisted pairs in control element
2. Drain wire in control element (bare copper wire)
3. Screened copper pt-foil
4. Insulation sheath (jacket) or PT-foil for control element
5. Power cores
6. Ground (earth) core

VIII. Transportation and Storage

The pump can be transported and stored in a vertical or horizontal position.



Always lift the pump by its lifting handle, never by the motor cable or the hose.

Make sure that the pump cannot roll or fall over and injure people or damage property.

The pump is frostproof as long as it is operating or is immersed in the liquid. If the pump is raised when the temperature is below freezing, the impeller may freeze.

The pump shall be run for a short period after being raised in order to discharge all remaining water.

A frozen impeller can be thawed by allowing the pump to stand immersed in the liquid for a short period before it is started. Never use a naked flame to thaw the pump.

For longer periods of storage, the pump must be protected against moisture and heat. The impeller should be rotated occasionally (for example every other month) to prevent the seals from sticking together.

After a long period of storage, the pump should be inspected before it is taken into operation. Pay special attention to the seals and the cable entry.

Follow the instructions under the heading “Before Starting”.

IX. Operation

Before Starting



Before starting work on the pump, make sure that the pump is isolated from the power supply and cannot be energized.

Make sure that the pump cannot roll or fall over and injure people or damage property.

Check that the visible parts on the pump and installation are undamaged and in good condition.

Check the oil level in the oil housing.

Remove the fuses or open the circuit breaker and check that the impeller can be rotated freely.

Check that the monitoring equipment (if any) works.

Check the direction of rotation. The impeller shall rotate clockwise, as viewed from above. When started, the pump will jerk in the opposite direction to the direction in which the impeller rotates. See the figure.

In the case of dry installation, check the direction of rotation through the inlet elbow access cover.

Transpose two phase leads if the impeller rotates in the wrong direction (3~).



In some installations the pump surface and the surrounding liquid may be hot. Bear in mind the risk of burn injuries.

Starting Jerk

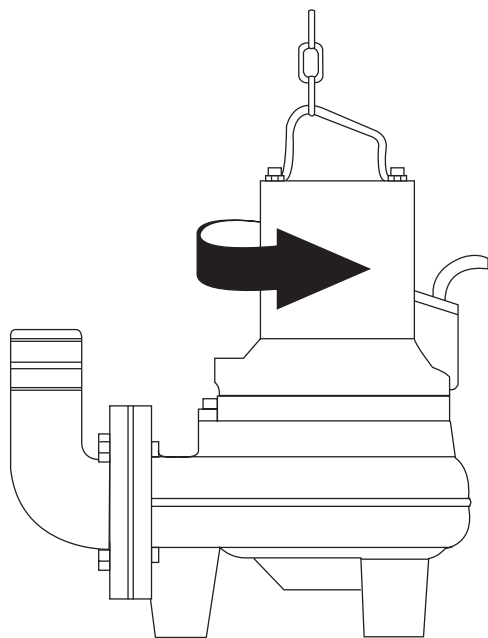

Watch out for the starting jerk, which can be powerful.

X. Care and Maintenance



Before starting work on the pump, make sure that the pump is isolated from the power supply and cannot be energized. This applies to the control circuit as well.

NOTE FOR XP-VERSION: All work on the explosion-proof motor section must be performed by personnel authorized by Goulds Water Technology. Goulds Water Technology disclaims all responsibility for work done by untrained, unauthorized personnel.

Make sure that the pump cannot roll or fall over and injure people or damage property.

The following points are important in connection with work on the pump:

- Make sure that the pump has been thoroughly cleaned.
- Beware of the risk of infection.
- Follow local safety regulations.

The pump is designed for use in liquids which can be hazardous to health. In order to prevent injury to the eyes and skin, observe the following points when working on the pump:

- Always wear goggles and rubber gloves.
- Rinse the components in water after dismantling.
- The oil housing may be under pressure. Hold a rag over the oil screw (oil plug) to prevent splatter.

Proceed as follows if hazardous chemicals have splashed into your eyes:

- Rinse your eyes immediately in running water for 15 minutes. Hold your eyelids apart with your fingers.
- Contact an eye specialist.

On your skin:

- Remove contaminated clothes.
- Wash your skin with soap and water.
- Seek medical attention, if required.

Inspection

Regular inspection and preventive maintenance ensure more reliable operation.

The pump should be inspected at least once a year, but more frequently under severe operating conditions.

Under normal operating conditions, the pump should have a major overhaul in a service shop at least every third year for permanent installation and every year for portable pumps. This requires special tools and should be done by an authorized service shop.

If the seals have been replaced an inspection of the oil is recommended after one week of operation.

NOTE: Regular check of the condition of the lifting handle and chain is important.

XI. Oil Change

A check of the condition of the oil can show whether there has been leakage. **NOTE: Air/oil mixture can be confused with water/oil mixture.**

Insert a tube (or hose) into the oil hole. Cover the top end of the tube and take up a little oil from the bottom.

Change the oil if it contains too much water, i.e. if it is heavily emulsified (cream-like), or if the oil housing contains free water. Check again one week after changing the oil.



The oil housing may be under pressure. Hold a rag over the oil plug to prevent splatter.

1. Lay the pump on its side on a bench or over two supports. Unscrew the oil housing screw (oil plug) marked “oil out”. Emptying the oil must be done through the “oil out” hole.
2. Turn the pump. Unscrew the “oil in” oil hole screw/plug. In order to drain out all oil, the pump must be raised upright for a short while during drainage.
3. Replace the o-rings under the oil housing screws (plugs) with new ones.
4. Install the “oil out” screw/plug and fill with oil through the other hole. It is important that the oil be added through the hole marked “oil in” since the oil housing must contain some air for pressure equalization. The pump should be tilted slightly and put down again horizontally in order to get the full amount of oil in.

A paraffin oil with viscosity close to ISO VG15 is recommended (e.g. Mobil Whiterex 309). The pump is delivered from factory with this type of oil.

In applications where poisonous properties are of less concern, a mineral oil with viscosity up to ISO VG32 can be used.

Please see Parts List for the correct volume.

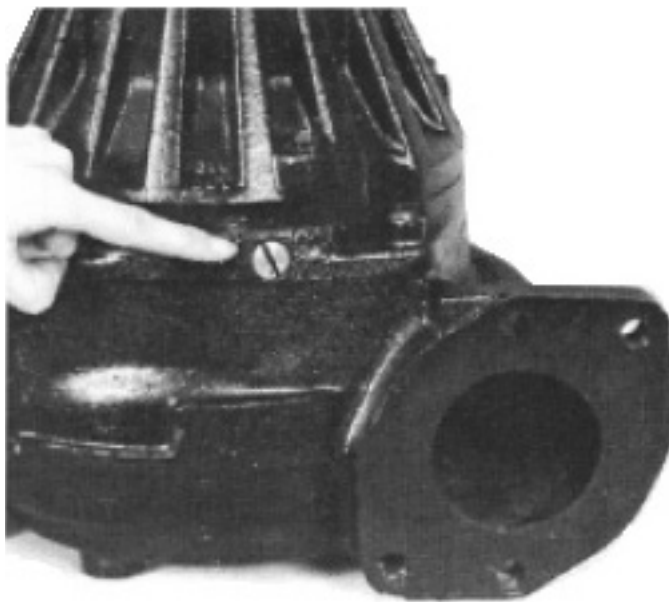

Figure 1

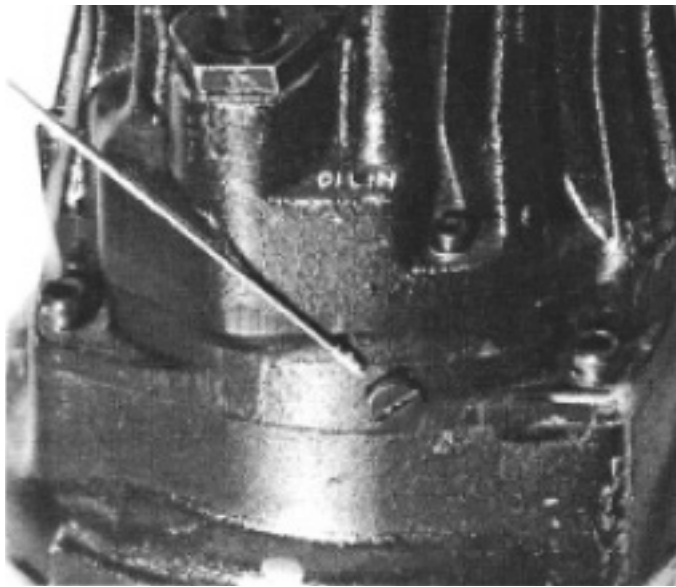

Figure 2

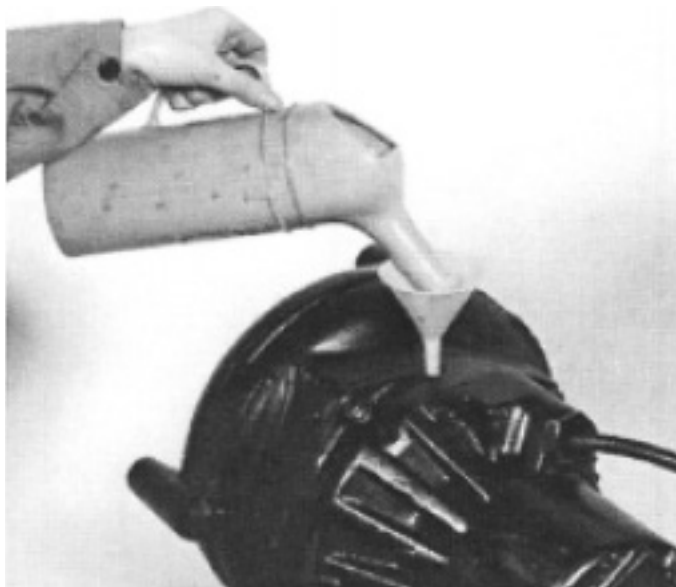

Figure 3

XII. Service Log

Most Recent Service Date	Pump No.	Hours of Operation	Remarks	Sign.

LIMITED CONSUMER WARRANTY

For goods sold for personal, family or household purposes, Seller warrants the goods purchased hereunder (with the exception of membranes, seals, gaskets, elastomer materials, coatings and other "wear parts" or consumables all of which are not warranted except as otherwise provided in the quotation or sales form) will be free from defects in material and workmanship for a period of one (1) year from the date of installation or eighteen (18) months from the product date code, whichever shall occur first, unless a longer period is provided by law or is specified in the product documentation (the "Warranty").

Except as otherwise required by law, Seller shall, at its option and at no cost to Buyer, either repair or replace any product which fails to conform with the Warranty provided Buyer gives written notice to Seller of any defects in material or workmanship within ten (10) days of the date when any defects or non-conformance are first manifest. Under either repair or replacement option, Seller shall not be obligated to remove or pay for the removal of the defective product or install or pay for the installation of the replaced or repaired product and Buyer shall be responsible for all other costs, including, but not limited to, service costs, shipping fees and expenses. Seller shall have sole discretion as to the method or means of repair or replacement. Buyer's failure to comply with Seller's repair or replacement directions shall terminate Seller's obligations under this Warranty and render this Warranty void. Any parts repaired or replaced under the Warranty are warranted only for the balance of the warranty period on the parts that were repaired or replaced. The Warranty is conditioned on Buyer giving written notice to Seller of any defects in material or workmanship of warranted goods within ten (10) days of the date when any defects are first manifest.

Seller shall have no warranty obligations to Buyer with respect to any product or parts of a product that have been: (a) repaired by third parties other than Seller or without Seller's written approval; (b) subject to misuse, misapplication, neglect, alteration, accident, or physical damage; (c) used in a manner contrary to Seller's instructions for installation, operation and maintenance; (d) damaged from ordinary wear and tear, corrosion, or chemical attack; (e) damaged due to abnormal conditions, vibration, failure to properly prime, or operation without flow; (f) damaged due to a defective power supply or improper electrical protection; or (g) damaged resulting from the use of accessory equipment not sold or approved by Seller. In any case of products not manufactured by Seller, there is no warranty from Seller; however, Seller will extend to Buyer any warranty received from Seller's supplier of such products.

Goulds Water Technology Policy Concerning Online Sales to Consumers. Homeowners using the Internet to locate information regarding residential water systems, residential wastewater systems, controls and tanks may discover several sites offering a direct-to-consumer purchasing opportunity. Residential water and wastewater systems are mission critical applications and are designed to be installed by qualified professionals. Goulds Water Technology has an extensive nationwide network of distributors and dealers, including authorized resellers. For a complete view of Goulds Water Technology recognized distributors, dealers and authorized resellers, please refer to our locator at: <http://goulds.com/sales-service/>

No warranty is offered on Goulds Water Technology equipment purchased over the Internet, including web-based options from unauthorized retailers. This policy is necessary to ensure that Goulds Water Technology equipment is installed properly, in compliance with applicable laws, rules and codes, in a manner that addresses safety concerns and the proper performance of Goulds Water Technology equipment.

THE FOREGOING WARRANTY IS PROVIDED IN PLACE OF ALL OTHER EXPRESS WARRANTIES. ALL IMPLIED WARRANTIES, INCLUDING BUT NOT LIMITED TO THE IMPLIED WARRANTIES OF MERCHANTABILITY AND FITNESS FOR A PARTICULAR PURPOSE, ARE LIMITED TO ONE (1) YEAR FROM THE DATE OF INSTALLATION OR EIGHTEEN (18) MONTHS FROM THE PRODUCT DATE CODE, WHICHEVER SHALL OCCUR FIRST. EXCEPT AS OTHERWISE REQUIRED BY LAW, BUYER'S EXCLUSIVE REMEDY AND SELLER'S AGGREGATE LIABILITY FOR BREACH OF ANY OF THE FOREGOING WARRANTIES ARE LIMITED TO REPAIRING OR REPLACING THE PRODUCT AND SHALL IN ALL CASES BE LIMITED TO THE AMOUNT PAID BY THE BUYER FOR THE DEFECTIVE PRODUCT. IN NO EVENT SHALL SELLER BE LIABLE FOR ANY OTHER FORM OF DAMAGES, WHETHER DIRECT, INDIRECT, LIQUIDATED, INCIDENTAL, CONSEQUENTIAL, PUNITIVE, EXEMPLARY OR SPECIAL DAMAGES, INCLUDING BUT NOT LIMITED TO LOSS OF PROFIT, LOSS OF ANTICIPATED SAVINGS OR REVENUE, LOSS OF INCOME, LOSS OF BUSINESS, LOSS OF PRODUCTION, LOSS OF OPPORTUNITY OR LOSS OF REPUTATION.

Some states do not allow limitations on how long an implied warranty lasts, so the above limitation may not apply to you. Some states do not allow the exclusion or limitation of incidental or consequential damages, so the above exclusions may not apply to you. This warranty gives you specific legal rights, and you may also have other rights which may vary from state to state.

To make a warranty claim, check first with the dealer from whom you purchased the product or visit www.xylem.com for the name and location of the nearest dealer providing warranty service.



Xylem, Inc.
2881 East Bayard Street Ext., Suite A
Seneca Falls, NY 13148
Phone: (866) 325-4210
Fax: (888) 322-5877
www.gouldswatertechnology.com

Goulds is a registered trademark of Goulds Pumps, Inc. and is used under license.
© 2016 Xylem Inc. IM070 Revision Number 5 November 2016